

Maximum load for slides: 25 kg
 Slide lengths: 300, 350, 400, 450, 500, 550 mm
 Height adjustment: 0 to 4 mm

LW - internal cabinet width
 SKW - internal drawer width

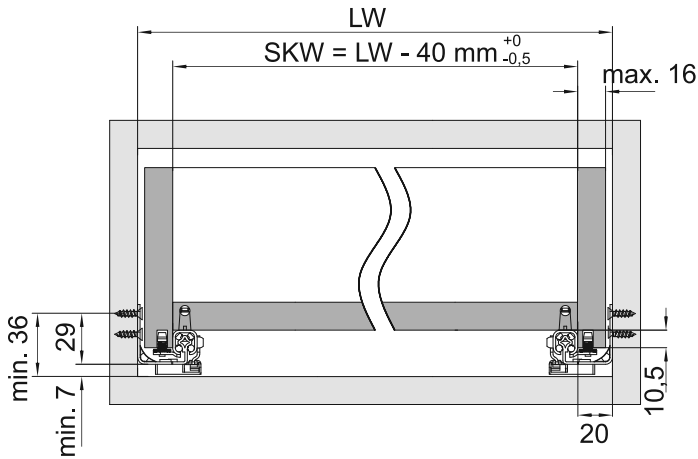

NL - nominal length of slide
 LT - internal cabin depth
 SKL - drawer depth
 Drawer side thickness: max. 16 mm

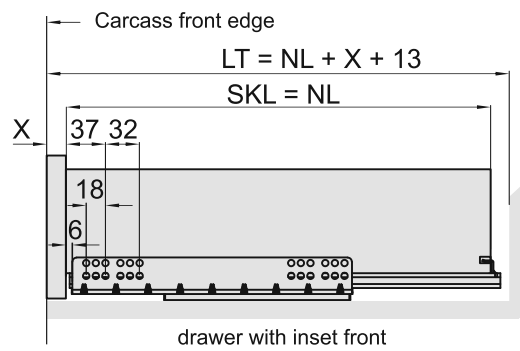
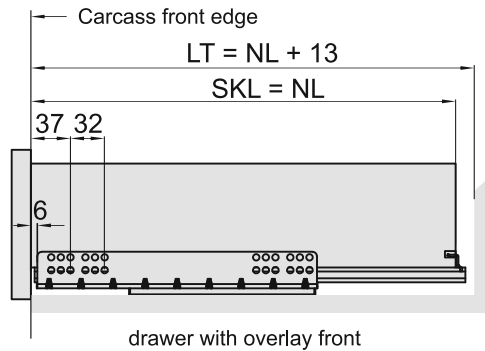

Drawer slide positioning

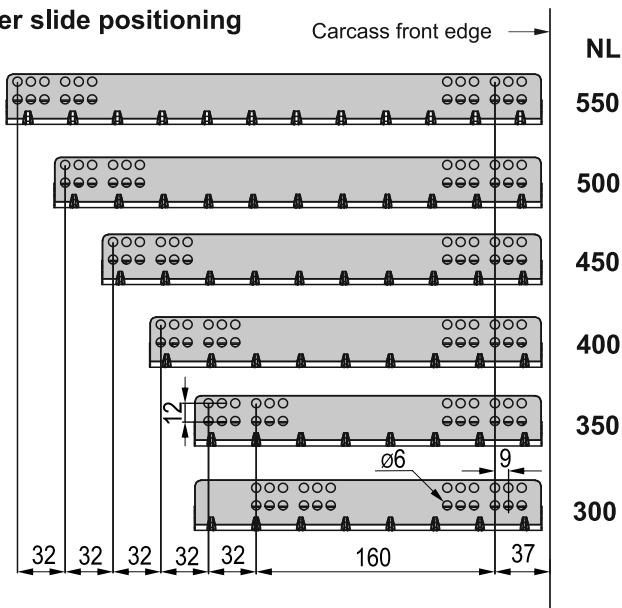

Slide length

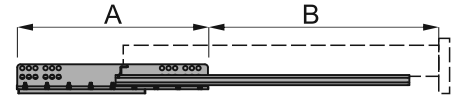

NL	300	350	400	450	500	550
A	233	235	263	295	327	359
B	238	276	314	352	390	440

Mounting dimensions for drawers

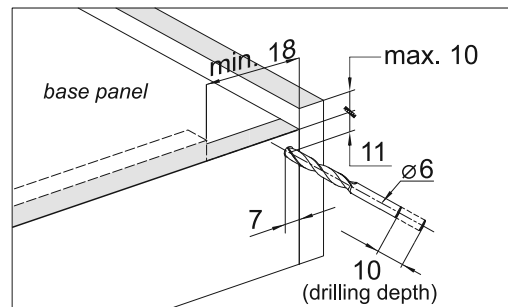

Mounting dimensions for base panel

NL	300	350	400	450	500	550
X1	188,5	221,5	249,5	283,5	309,5	338,5

